



SAFEPRO WARNING LINE INSTALLATION MANUAL



Assemble and use as specified in the instructions manual to meet OSHA compliance regulations, as stated, under standards-29 CFR, 1910.28, 1910.29 & 1926.501, 1926.502, and CAL-OSHA ARTICLE 30, 1730.

Installation tools required: 1/8" hex key, 3/16" hex key, wire rope cutters, torque wrench with 5/16" Allen socket.

Tools recommended: 1/4" hexsocket bit, socket adaptor,

cordless impact driver

Warning: Failure to comply with manufacturer's installation and use procedure may result in property damage, personal injury or death. Only competent persons experienced in these installation methods shall install SafePro equipment. If method of use is not understood, do not attempt to use the equipment.



CONTACT US

Phone: (877) 723-3570
info@safeprosafety.com
safeprosafety.com

TABLE OF CONTENTS

System Compliance and Pre-Installation Message3

Definitions.....4

SafePro Warning Line Parts List.....5

SafePro Warning Line Layout.....6

SafePro Warning Line Outrigger Assembly7

SafePro Warning Line Cable Assembly8

SafePro Warning Line Flag Attachment..... 9

Installation Requirements 10

SafePro Warning Line Installation Procedures11

System Inspection & Disclaimer 12



SYSTEM COMPLIANCE

- System is designed to comply with OSHA Standards 29 CFR 1910.28 & 1910.29, 29 CFR 1926.501 & 1926.502, and Cal-OSHA Article 30, Section 1730.
- System may be used as a designated area on a low-slope roof as defined by OSHA Standard 29 CFR 1910.28. A low slope roof means a roof that has a slope less than or equal to 4:12 pitch.
- When used with ballasted bases, the warning line system is limited to a slope that is less than or equal to 1:12 pitch.
- Designated areas, as defined by OSHA 1910.28, must be erected at least 6ft from the roof edge and may be used only to conduct work that is both infrequent and temporary.
- As per OSHA Standard 29 CFR 1910.29(d)(3), when mobile mechanical equipment is used to perform work within a designated area, the warning line must be erected not less than 10ft from the unprotected side or edge that is perpendicular to the direction in which the mechanical equipment is operated.
- When the system is used to assemble a controlled access zone to comply with OSHA Standard 29 CFR 1926.501(b)(9), the system must be installed in accordance with OSHA Standard 1926.502(g). When used as a warning line to comply with OSHA Standard 29 CFR 1926.501(b)(10), the system must be installed in accordance with OSHA Standard 1926.502(f). Certain specialty trade workers may require a greater setback from the roof edge. Consult specific Federal and State OSHA rules and regulations prior to installation.
- Warning lines installed to comply with Cal-OSHA Article 30, Section 1730 must be placed in accordance with those provisions.
- When used with ballasted bases, the warning line system is designed to withstand an ASCE 7-16 Ultimate Wind Load of up to 120 MPH on a Risk Category II building with Exposure Category B. The standard design configuration may be reconfigured by SafePro to accommodate alternate site conditions if required.

PRE-INSTALLATION MESSAGE

- CAUTION: This system is to be used only for its intended use as defined within the System Compliance guide above. This system is NOT to be used as a guardrail.
- Verify that the surface the SafePro Warning Line will be installed onto is capable of supporting the product and personnel installing it. A complete assessment of the entire surrounding areas should be made to determine if the walking and working surfaces have the strength and structural integrity to support users safely.
- Only install Warning Line on flat dry clean surfaces under conditions where adequate illumination is provided.
- Never erect Warning Lines near electrical wires. Keep a minimum of ten (10) feet from power lines.
- Never install or use Warning Lines on top of gravel, metal, trowel finished concrete, or similar surfaces without speaking with a SafePro representative.
- Routine inspection of all parts is recommended. If damaged parts are found, replace with new parts. Contact SafePro immediately.

DEFINITIONS

- **COUNTERWEIGHTED BASE:** Supporting non-penetrating base for warning line system.
- **COMPETENT PERSON:** Defined by 29 CFR1926.32 (f) as someone ...who is capable of identifying existing and predicable hazards in the surroundings or working conditions which are unsanitary, hazardous, or dangerous to employees, and who has authorization to take prompt corrective measures to eliminate them...”
- **CONTINUOUS RUN:** A single or series of warning line support posts installed in a continuous, without interruption, straight line.
- **LEADING EDGE:** The edge of a floor, roof, or formwork for a floor or other walking/working surface (such as the deck) which changes location as additional floor, roof or deck, or formwork sections are placed or constructed. A leading edge is considered an unprotected side and edge.
- **QUALIFIED PERSON:** Defined by 29 CFR 1926.32 (m) as someone “...who, by possession of a recognized degree, certificate, professional standing, or who by extensive knowledge, training, and experience, has successfully demonstrated his/her ability to solve or resolve problems relating to the subject matter, work, or the project...”
- **STRUCTURE MOUNTED BASE:** Baseplate designed for compatibility with and connection to existing structural substrate such as standing seam, metal roofing, or other substrates as approved and designed by SafePro.
- **UNPROTECTED SIDE AND EDGE:** Any side or edge of a walking/working surface, e.g. floor, roof, ramp, or runway where there is no wall or guardrail system.

SAFEPRO WARNING LINE GUARDRAIL PARTS LIST:

- **TERMINATION SUPPORT STANCHION:** Vertical post designed to support the termination of a warning line continuous run. Standard finish is Pre-Galvanized.
- **INTERMEDIATE SUPPORT STANCHION:** Vertical post designed with integral clamp support as cable system passes through to an adjacent intermediate or termination support stanchion. Standard finish is Pre-Galvanized.
- **COUNTERWEIGHTED BASE:** Cast steel with three receivers that the corresponding Guardrail Panel or Vertical Post is placed within. Standard finish baseplate is hot dip galvanized.
- **FLAG:** Safety yellow flag is designed to ensure visibility from at least 25ft when installed onto the supporting at 6ft on center minimum. Provided as exterior grade ABS.
- **FLAG SUPPORT CLIP:** Aluminum flag clip is designed to support connection of the flag to the supporting PVC coated cable.
- **FLAG PLACEMENT CLAMP:** Aluminum clamp is secured to the warning line cable at the center of the flag support clip to prevent excessive lateral movement of the clip.
- **PVC COATED CABLE:** Steel wire cable with yellow PVC coating
- **OUTRIGGER ASSEMBLY:** Additional offset base assembly designed to support warning line termination or direction change greater than 30 degrees.

ADDITIONAL COMPONENTS:

- **OPTIONAL RUBBER ROOF PADS:** The Rubber Roof Pad is a protective accessory that withstands environmental conditions and protects the roofing membrane surface from direct contact with the counterweighted base.

FIGURE 1: WARNING LINE LAYOUT

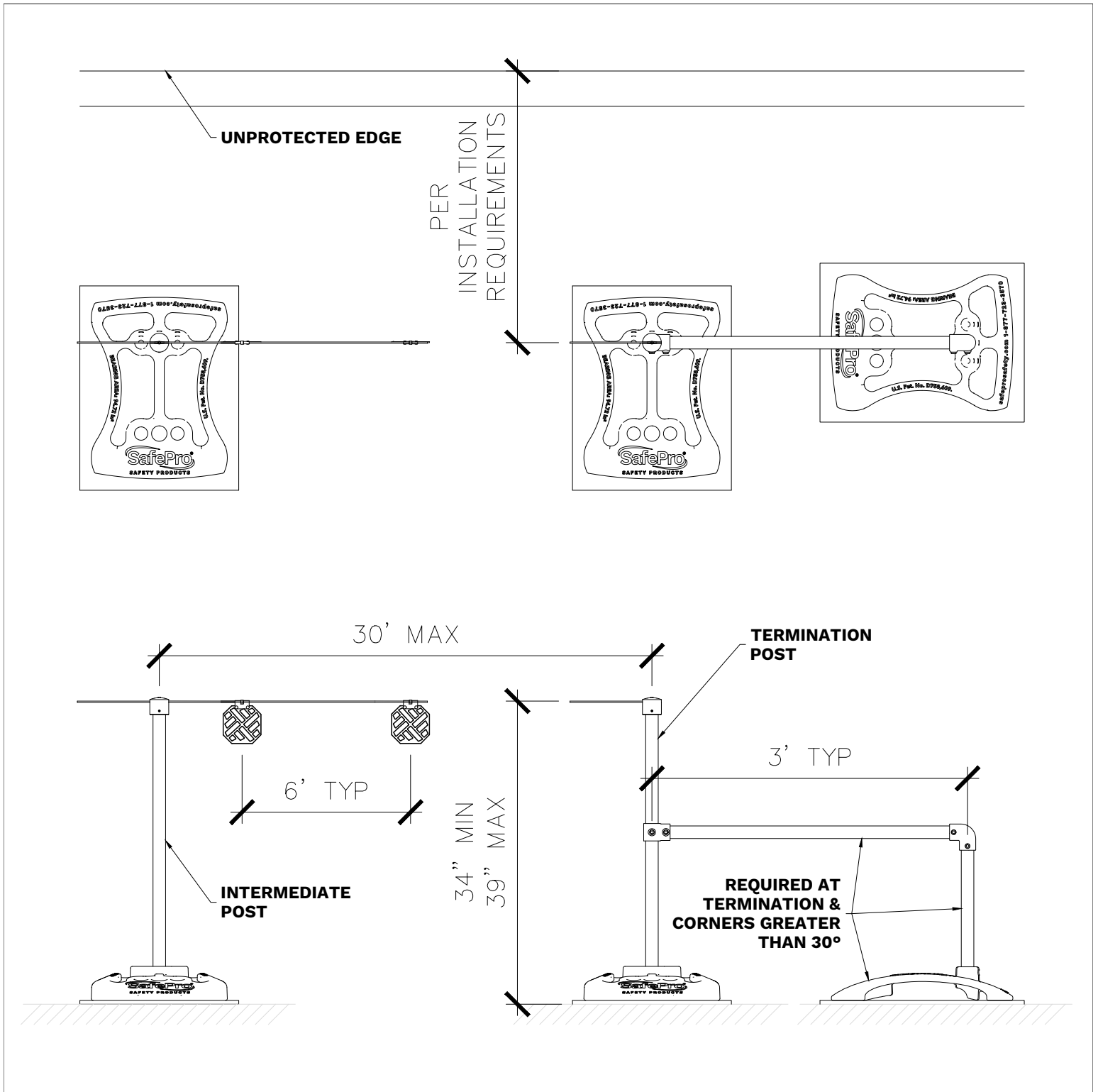
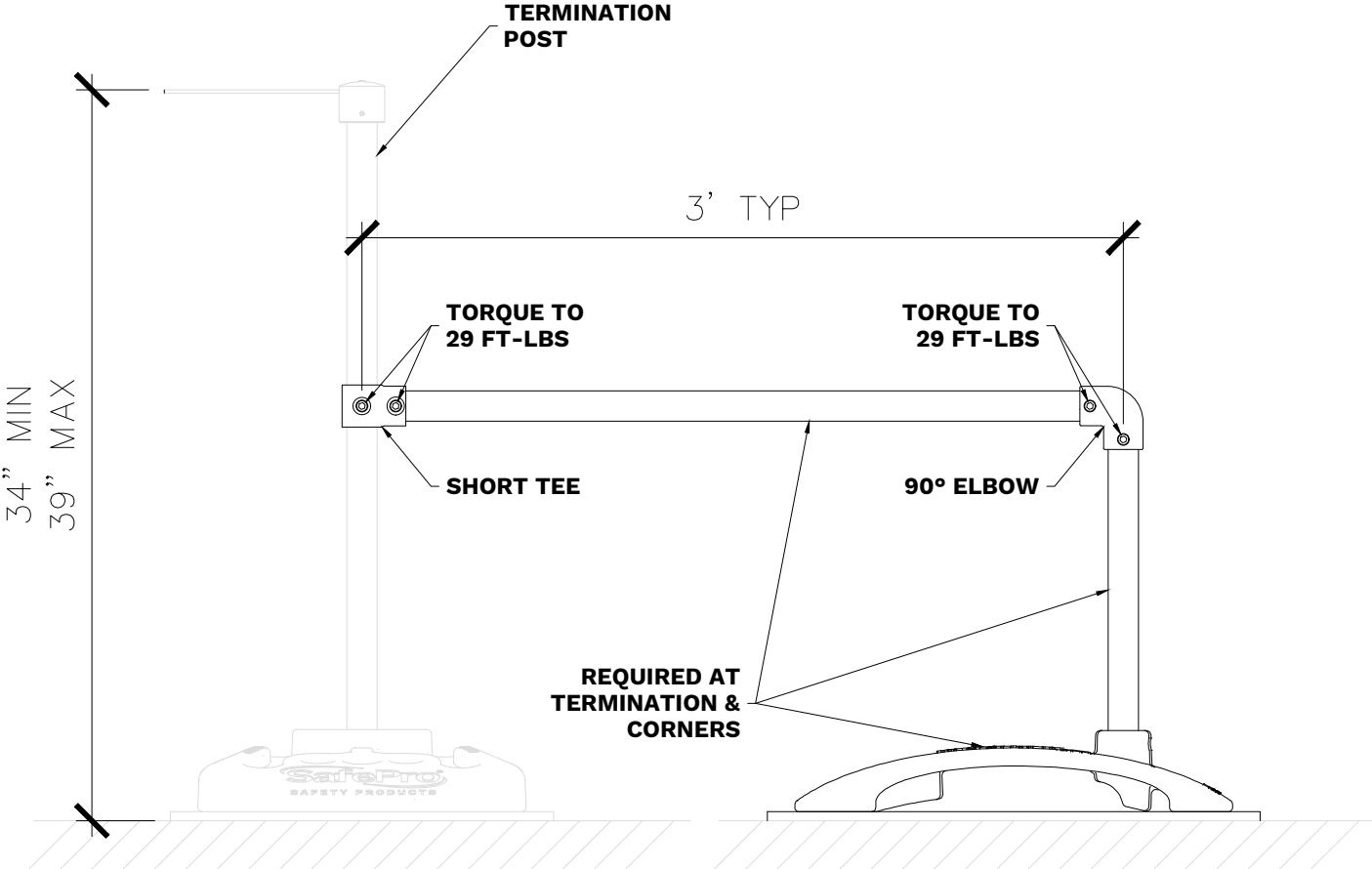

FIGURE 2: WARNING LINE OUTRIGGER ASSEMBLY



OUTRIGGER ASSEMBLY

FIGURE 3: WARNING LINE CABLE ASSEMBLY

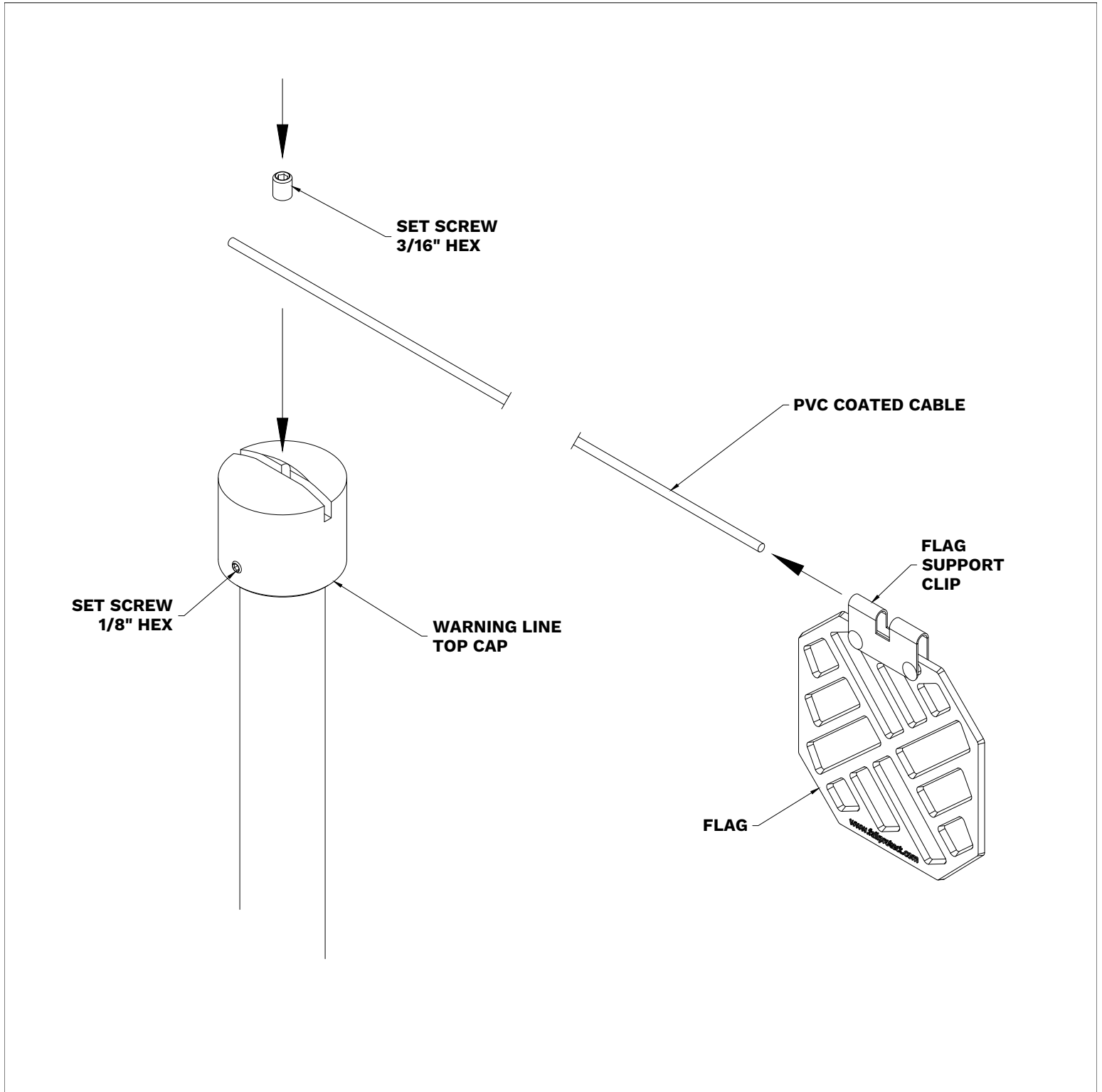
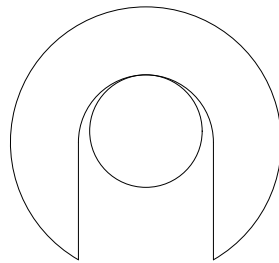
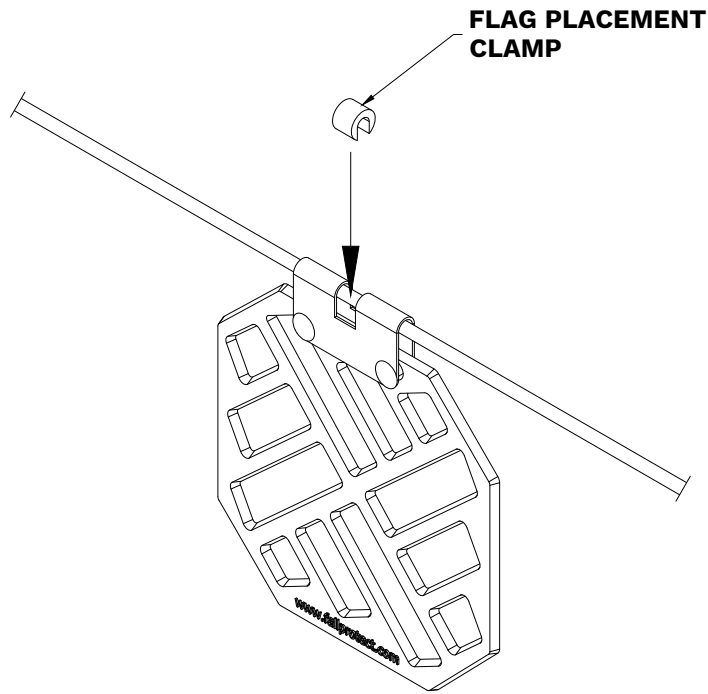
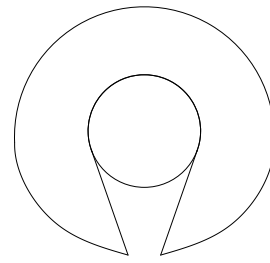

FIGURE 4: WARNING LINE FLAG ATTACHMENT



NOT CRIMPED



CRIMPED

INSTALLATION REQUIREMENTS

1. Compliant offset distance of warning line from edge varie per application. Refer to applicable OSHA or Cal/OSHA regulations as detailed within the system compliance section of this manual.
2. For applications installed in accordance with OSHA 1910.29 & 1926.502(f), the warning line should be erected not less than 6 feet from the unprotected edge, but not less than 10 feet from the unprotected edge that is perpendicular to the direction in which mechanical equipment is operated (refer to Figure 1).
3. Spacing between support stanchions may not exceed 30 feet.
4. System should be used on a flat surface not to exceed 1:12 pitch.
5. Integrated rubber protection pad may be used on roof membrane for roof protection. Do not install on slippery surfaces such as metal or trowel finished concrete.
6. Remove all loose gravel and/or materials in the vicinity of the counterweighted base. Bases must be placed on sound substrate.
7. Outrigger assemblies must be placed at warning line terminations or direction changes that are greater than 30 degrees.
8. Tighten all set screws to 29 ft-lbs.

SAFEPRO WARNING LINE INSTALLATION PROCEDURES

- Layout the job first by measuring and spacing the bases. Failure to properly measure and plan ahead will result in difficulty in moving the assembled system to another location. Place and connect counterweighted outriggers at termination ends and where direction change is greater than 30 degrees. Connect outrigger bases to stanchions using pipe and fittings as pictured in Figure 2.
- If using Counterweighted Bases, be sure the bases are in the correct orientation with receivers oriented toward the closest building edge. Next, insert warning line stanchions into one of the three receivers in the counterweighted base. If using structure mounted bases, fasten the bases to the structure per project specific instructions.
- Use 5/16” Allen Wrench to tighten the set screws of the receivers at each base and any outrigger pipe fittings. Torque to 29 ft-lbs. Check tension twice on set screws to make sure they all have been tightly secured. To disassemble, reverse the process.
- Connect one end of PVC coated cable to a termination support stanchion by placing the cable in the top slot of the warning line top cap, secure the cable with the set screw and tighten with a 3/16” hex key. Secure warning line top cap to the termination support stanchion by tightening the set screw with a 1/8” hex key (Refer to figure 3). Thread preassembled flags through open end of cable and connect the flag to the cable at 6ft on center using provided flag placement clamp. The flag placement clamp should be crimped onto the cable using a swage tool (refer to figure 4). The crimp should be tight enough to prevent lateral movement, but with care as not to damage the cable.
- Connection should be made to ensure that pulling on one section of the line will not result in reduced slack in an adjacent line prior to tipping of the stanchion. Ensure that the finished warning line cable elevation is not less than 34” and not higher than 39” above the finished roof.
- Cut wire rope and make connection at terminating end(s)

*Approved fall protection must be utilized while installing warning line system where fall hazards exist.

SYSTEM INSPECTION

- System shall be inspected by an authorized person for defects, damage, or deterioration prior to each use. Periodic inspections should be conducted by a competent person at intervals not to exceed 12 months.
- Any suspected defective equipment shall be removed from service.
- Initial signs of corrosion should be treated with a wire brush for removal, and subsequently apply paint or galvanizing spray as appropriate. Equipment with substantial corrosion or deterioration should be removed from service.
- Ensure warning line cable elevation and base locations meet installation requirements. Adjust tension or base placement as required.
- Ensure flags are placed at proper intervals and securely fastened to PVC coated cable. Ensure cable is properly connected and intermediate and termination warning line stanchions.
- Confirm proper connection of pipe to fittings and stanchions to counterweighted base receivers. If applicable, check connections to wall or roof structure.

DISCLAIMER

By accepting and using this Installation Manual, you release SafePro Safety Company and its affiliates of liability. The information in this Installation Manual is provided for informational purposes only and should not be relied upon as the sole source of guidance. Although every effort was made to ensure the information in this Installation Manual is factual, SafePro Safety Company and its affiliates do not assume responsibility for errors or oversights that may result from the use of the information contained within this Installation Manual. Any person making use of the contents in this Installation Manual assumes all liability arising for such use.