



Automatic Roof Hatch Opener

Ensure safety and compliance with the SafePro™ Automatic Roof Hatch Opener. This system allows for the unlocking, locking, and lifting of the hatch lid from ground level, providing secure ladder climbs and safer access through the roof opening. Operated via a convenient push button, it eliminates open hole violations in accordance with OSHA Regulation 1910.29. The 110V model offers reliable performance, making it an essential addition to any rooftop access point.

Features and Benefits:

- OSHA/ CalOSHA compliant
- Automatically open, close, lock and unlock
- Retrofit to any size or brand of hatch
- Simple installation
- Powered by 110VAC
- Access with keypad or remote
- Factory assembly to hatch available (hatch sold separately)



Specifications

- **Fit:** Standard hatch sizes
- **Type of Installation:** Simple, adjustable installation
- **Materials:** Heavy-duty, hot-rolled steel (HREW) with zinc-plated components
- **Mounting System:** Bracing back bracket actuator base: heavy-duty, hot-rolled steel (HREW), 18" x 5" x 3 1/2" with pre-bored adjustable mounting slots for 5/16" x 3/4" body bolts with black finish, repositioning pre-bored pivot holes for 3/8" zinc-plated bolts.
- **Hatch Lid Pivot Bracket Locking Assembly:** Repositioning pre-bored pivot holes and stops for 3/8" actuator pivot pin, pivot plates, and 3/8" bolts, zinc-plated. Mounted according to installation instructions.
- **Finish:** Black finish on steel components, zinc plating on bolts
- **Lift System:** Electric actuator system
- **Hardware:** High-quality, corrosion-resistant
- **Labels:** Safety and operational labels included
- **Installation:** Detailed installation instructions provided
- **Warranty:** One year limited warranty
- **US Patent number:** 8,915,023 (need to check)
- **Manufactured by:** SafePro Safety Products, Cleveland, OH

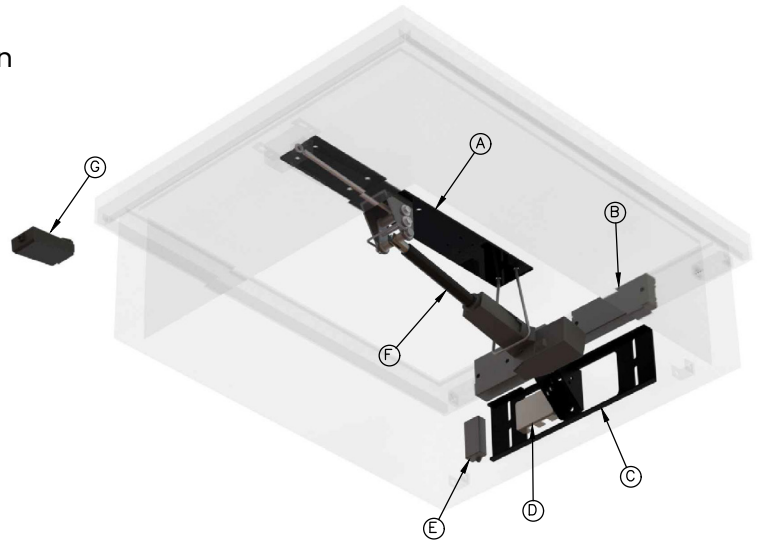

Parts

- | | |
|--------------------|-------------|
| A. Door Plate | E. Receiver |
| B. Back Up Battery | F. Actuator |
| C. Back Bracket | G. Keypad |
| D. Signal Box | |

Item Number	Description
300160	Automatic Roof Hatch Opener – 30" Hatch
300161	Automatic Roof Hatch Opener – 36" Hatch
300162	Automatic Roof Hatch Opener – 48" Hatch
300163	Automatic Roof Hatch Opener, Double Actuator – Larger Hatches
300114	Backup Battery, Lithium Ion
300294	Bluetooth Handheld Remote
300212	External Keypad
Labor	Factory Assembly to Roof Hatch (sold separately)

1 year manufacturer's parts warranty

1 year limited finish warranty

Manufactured By:

SafePro Safety Products, Cleveland, Ohio, USA

US Patent Number: 8,726,577

Your Personal SafePro Contact
